



Titan Dynamics

[Titan Dynamics Webpage](#)

[Visit our Facebook page](#)

[Join our Discord server](#)

# Titan Dynamics - Falcon

<https://www.titandynamics.org/3dhangar/p/titan-falcon>

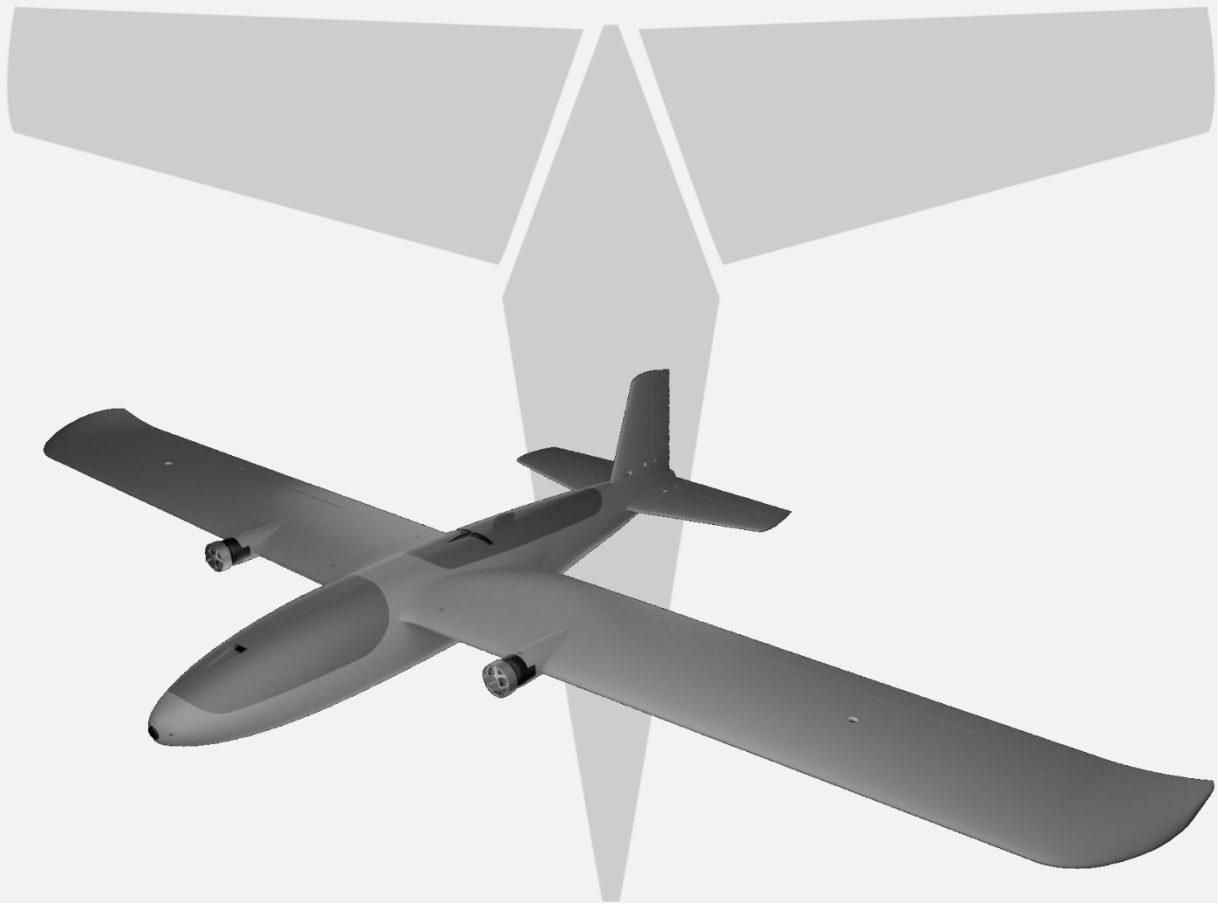

Build & User Manual  
Revision 1.2



## Contents

Section 1: Model Information .....	3
Section 2: Model Specifications & Performance.....	4
Section 3: Required Build Materials .....	5
Section 4: 3D printing .....	6
4.1: Things to know before you start printing. ....	6
4.2: Slicing the parts. ....	7
4.3 Parts List & Expected weights .....	10
Section 5: Assembly of 3D Printed Parts.....	11
Section 6: Final Setup & Tuning Tips .....	16
Section 7: Images .....	17



## Section 1: Model Information

Introducing the 2m wingspan Titan Falcon - our original flagship 3D printable long-range UAV (which is now superseded by the Falcon V2). Hundreds of Falcons have been printed across the world for various use-cases. Incredible attention to detail has gone into making Falcon lightweight yet structurally rigid. Wings, horizontal stabilizers and the vertical stabilizer are fully removable. The wings have large bays underneath for mounting the VTX and RX with ample separation. Dual elevators provide pitch redundancy while fully functional flaps allow for gentle takeoffs and landings. The Falcon offers a streamlined FPV camera nose as well as a multilevel deck for pan/tilt setups. There is a choice of 3 different wingtips (up, straight, or down) to fit your style preferences. You can also choose between a conventional tail or V-tail. There's even an optional fuselage piece that supports a mapping camera in the belly.

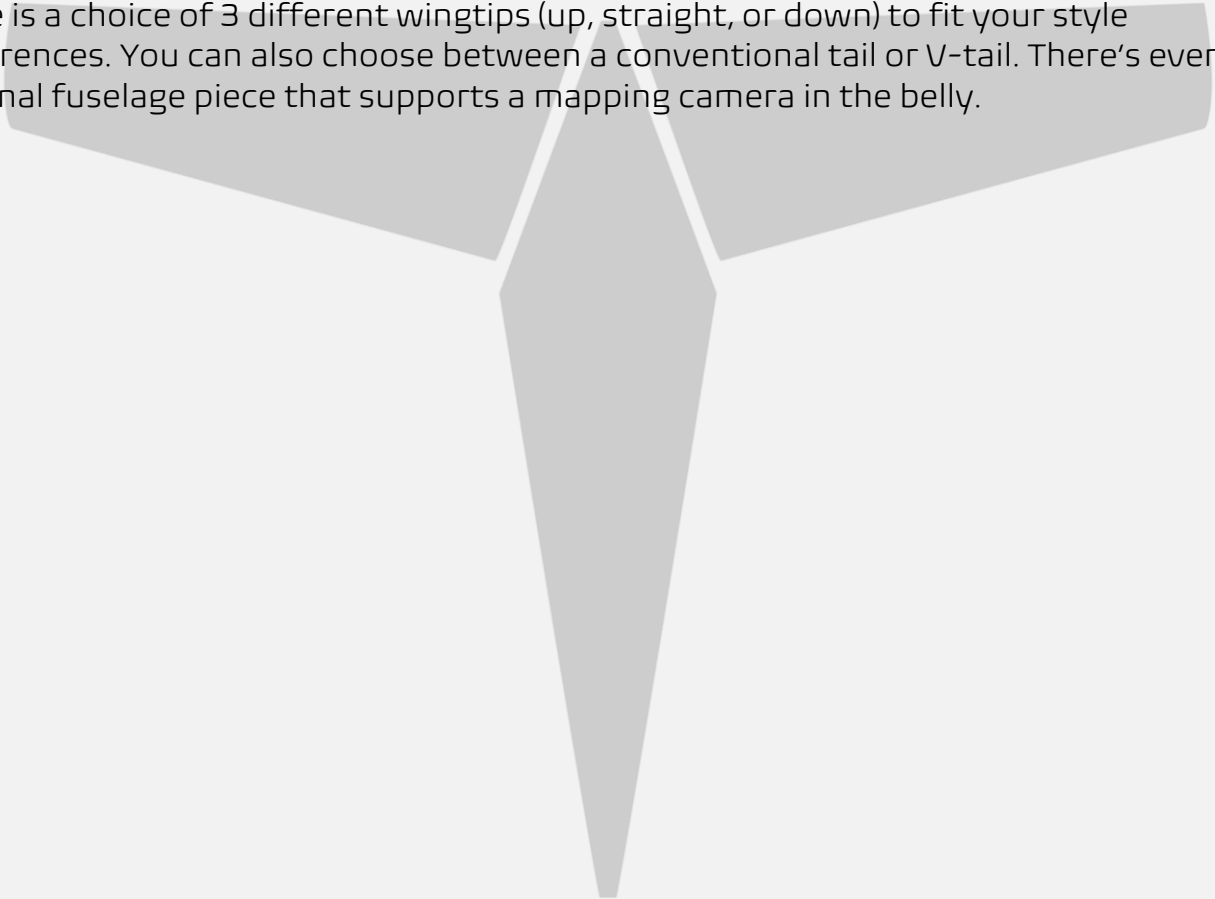



## Section 2: Model Specifications & Performance

### General Stats:

- Wingspan: 1940mm
- Wing area: 4605 cm<sup>2</sup>
- Maximum takeoff Weight: 6.6kg
- Efficiency: 1.5-1.8 Wh/km
- Cruise speed: 45-70 km/hr (28-40 mi/hr)
- Maximum prop diameter: 13in

### Aerodynamic Properties:

- Root airfoil: NACA 5412
- Tip airfoil: NACA 3410
- Root chord: 260mm
- Tip chord: 215mm
- Average Chord: 218mm
- Root incidence: 4°
- Tip incidence: 1°
- Aspect ratio: 8.37
- Max L/D: 12.9 @ 8° AOA
- Dihedral: 0.5°
- Sweep: 2°

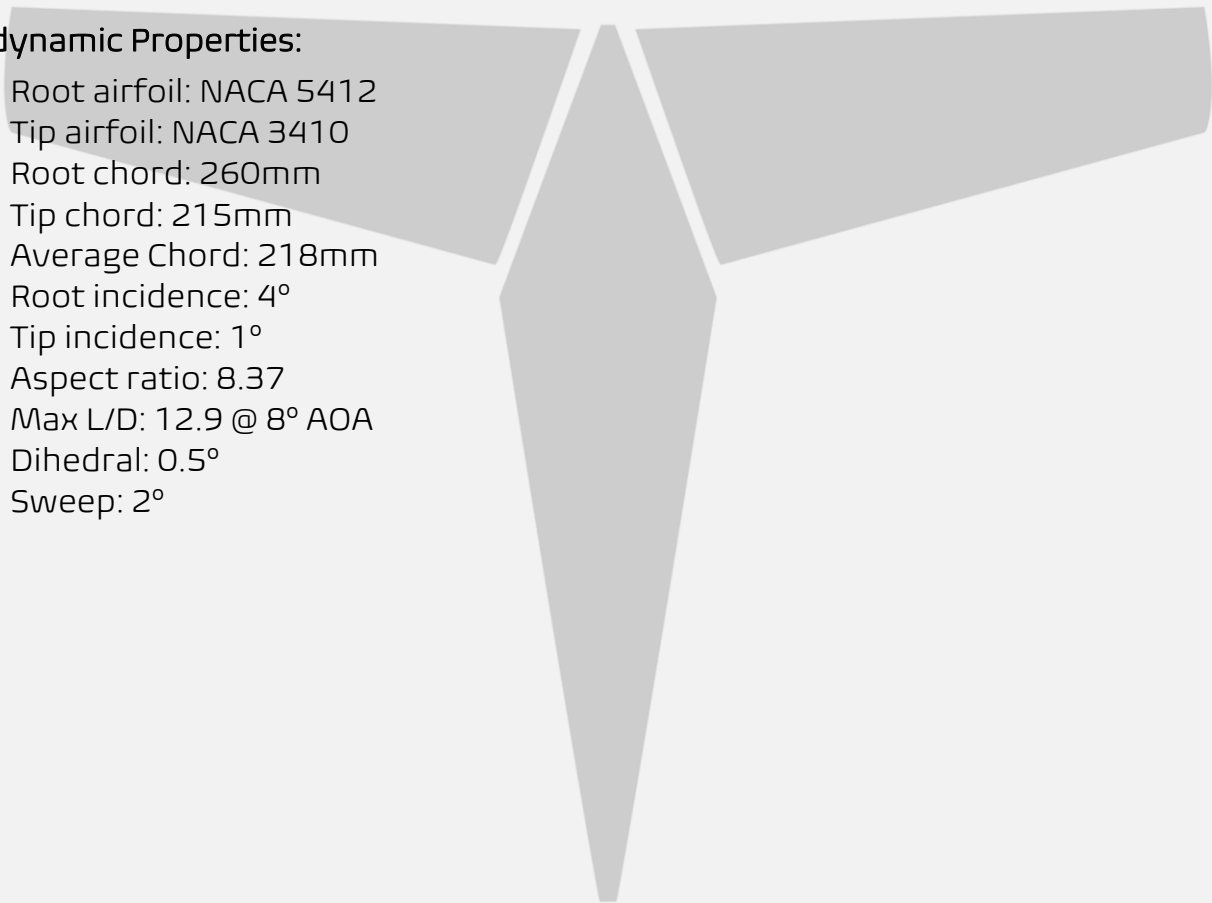



## Section 3: Required Build Materials

### Spars needed:

- (2) 12x1000mm hollow (main wing spars)
- (2) 10x500mm hollow (wing ends)
- (4) 4x600mm solid (aileron/flap hinge)
- (2) 4x600mm solid (optional for fuselage floor)
- (2) 4x500mm solid (hstabs)\*
- (2) 4x160mm solid (vstab)\*

\* Not needed if using V-Tail. Instead:

- (4) 4x300mm

### Recommended motor & prop:

19x25mm mounting hole.

3510 700kv (smaller motors ok, but less efficient).

12x8 CW and CCW (smaller props ok, but less efficient).

### Recommended electronics:

TBS crossfire / ELRS / Dragonlink.

5.8ghz / 1.2ghz video (19x19 camera).

Matek F405-WTE flight controller or similar.

Matek M8Q-5883 GPS/Compass or similar.

35a BLHeli ESCs (place in the fuselage).

(7) Emax ES08MAII servos. 2 for flaps, 2 for ailerons, 2 for elevators, 1 for rudder.

Example battery for beginners: 10,000mah 4S/6S Lipo.

Example battery for medium endurance: 4S8P 18650 28,000mah Li-Ion.

Example battery for max endurance: 4S12P 18650 42,000mah Li-Ion.

### Misc:

At least 2 800g rolls of Polymaker Polylite prefoamed LWPLA.

Polycarbonate, PETG or other high-temp filament for the motor mount.

Medium CA glue.

220x220x250 minimum size print bed (Ender 3).

Control horns ([this one](#)).

M3 threaded inserts (max 6mm height).

M3 bolts of various sizes.

6x3mm magnets for the hatch.



## Section 4: 3D printing

### 4.1: Things to know before you start printing.

1. Titan Dynamics strongly recommend using Polymaker Polylite prefoamed LWPLA for the best results. This filament is much easier to tune your printer for and has less stringing than active foaming filaments.
2. You likely will not get good results unless your printer is well maintained and calibrated, we would suggest learning how to check and adjust your printer to perform at its absolute best before starting. This website has useful guides: <https://teachingtechyt.github.io/calibration.html#intro>.
3. All the below guidance should be taken as a starting point only. Print a test piece and check things like retraction settings and fitment of the carbon rods in the wings for yourself as every printer is different. If the carbon rods are too tight, increase the "Hole Horizontal Expansion" setting in Cura (or the equivalent setting in other slicers).
4. **All our models are designed to be printed predominantly in LW-PLA filament. All fuselage, tail, and wing parts should be printed in LW-PLA**

There are 3 levels of infill / wall settings that we recommend for the LWPLA parts:

1. Maximum efficiency: 3% cubic subdivision, single wall
2. Balanced efficiency and strength: 5% cubic subdivision, single wall
3. Maximum strength: 8% cubic subdivision, single wall

#### Notes:

- For the best flight characteristics and maximum range, LWPLA parts should be printed with single wall and 3% cubic subdivision infill.
- Cubic subdivision infill can be increased to 5 or 8% to increase durability, but this will have an impact on maximum payload capacity (battery), and range by extension. We recommend and use 3% cubic subdivision infill as it has been tested to survive 6.4G in flight, but some may desire greater general durability when handing/carrying the model around etc. It will still break if you crash it!

Polycarbonate, PETG or other high-temp filament should be used for the motor nacelle caps and wing bay covers.

- High temp Polycarbonate or PETG parts should be double wall and high infill (25%).



## 4.2: Slicing the parts.

We recommend using Cura slicer version 5.1.1. [This link](#) can be used to download our own slicer profile.

### Part Orientation

It is necessary to orient each part correctly on the build plate to avoid disconnected overhangs. Take care when doing this as the entire model is designed to be printed with no supports. If you orient some parts wrong, the print will fail. It may also be necessary to rotate and carefully position some parts to fit within the build area on smaller printers.

Examples for part orientation:

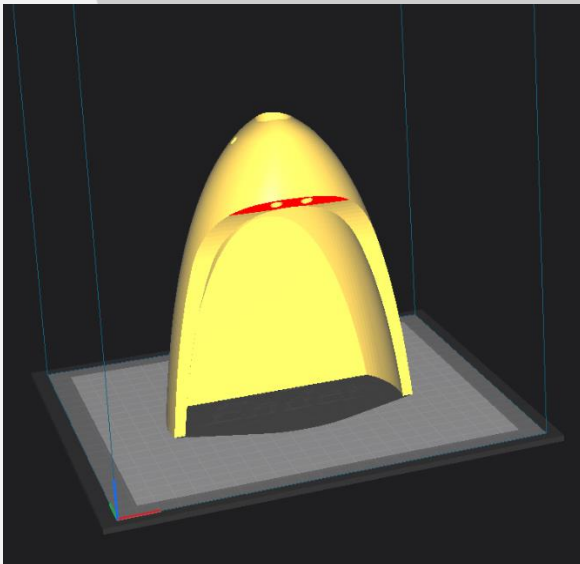

Fuse 1

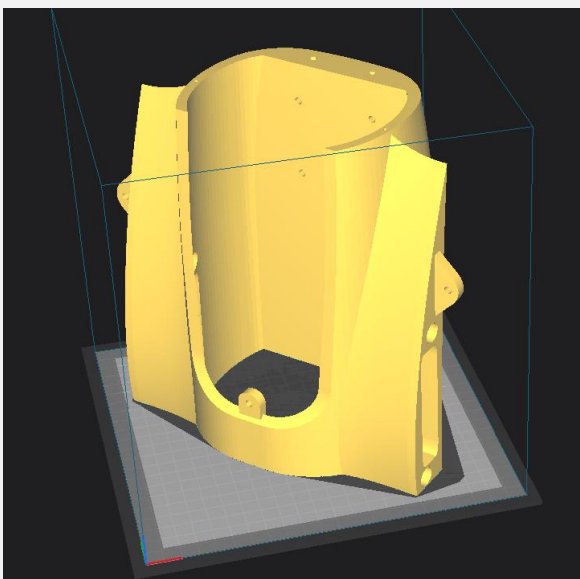

Fuse 3

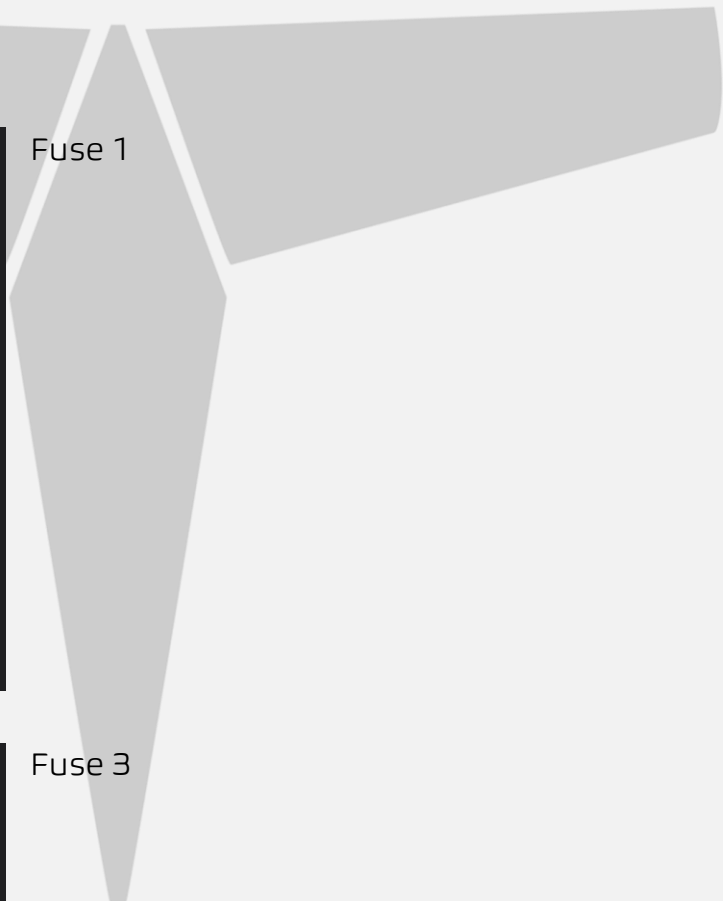

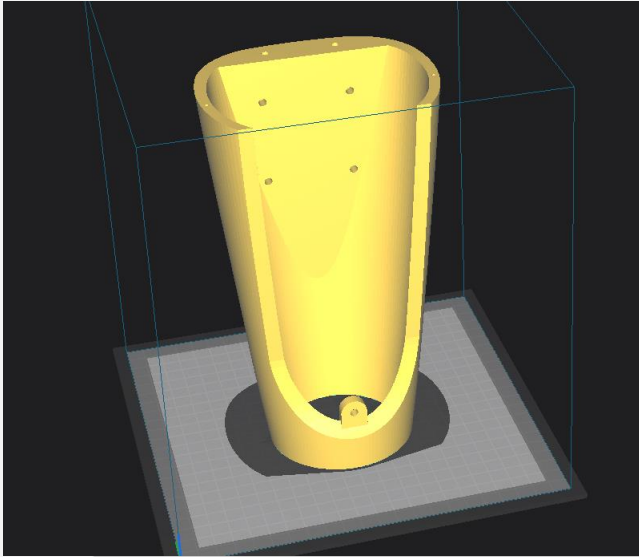

Fuse 4

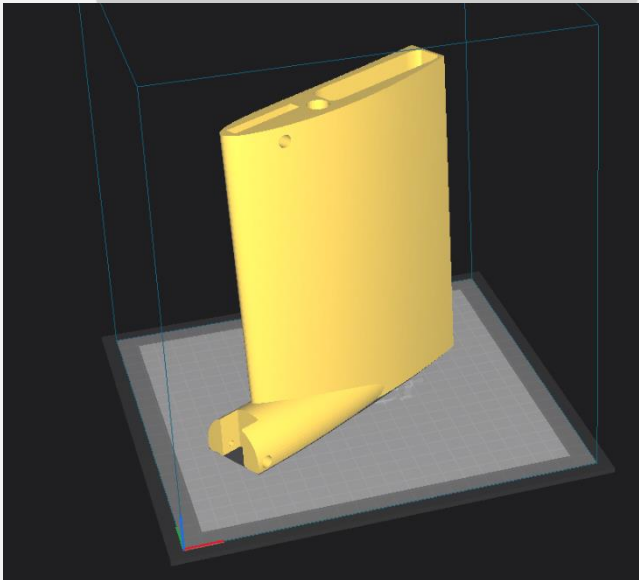

Wing 1

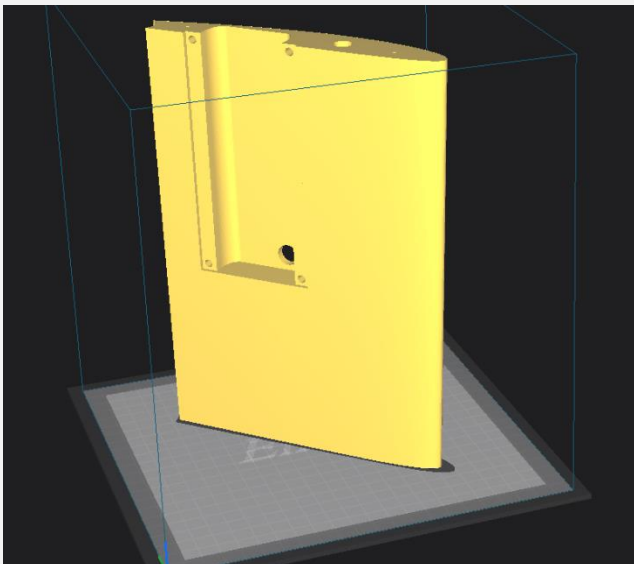

Wing 3

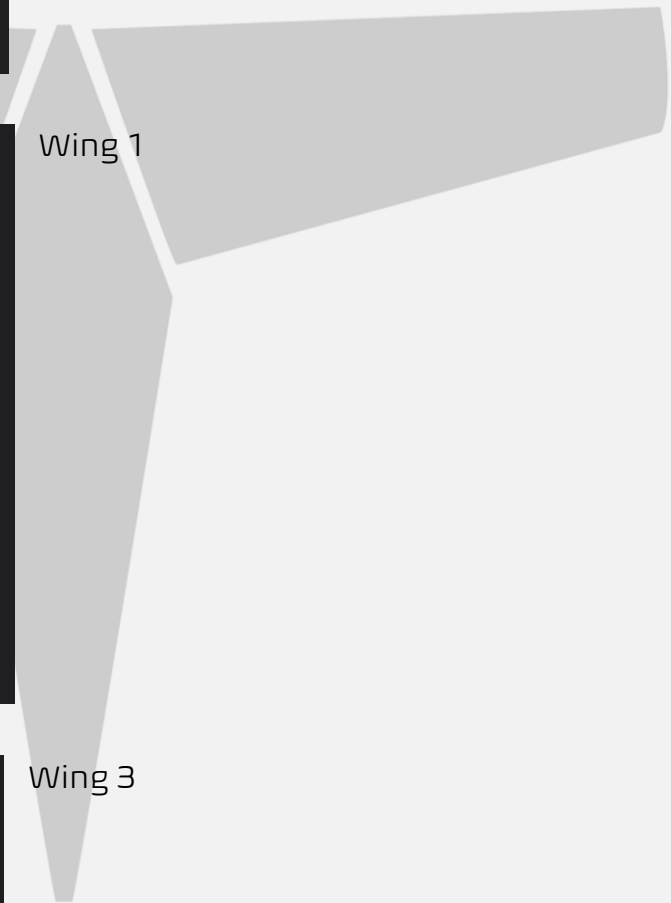





## Bed Adhesion and warping

When printing tall parts like this model requires, having good print adhesion to the bed is a necessity. Ideally you will print each part without any extra aids however this may not be possible for many, especially those printing without an enclosure for their printer. A full brim can be used but this will typically have mixed results. If it works for you, use a glue stick on the print surface to improve adhesion. Cura also has a plugin that can be used to help with bed adhesion and avoid warping.

Cura Marketplace, TabAntiWarping Plugin.

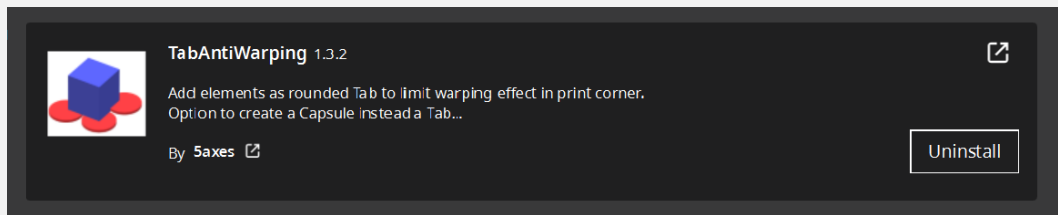

When installed, use the new icon at the bottom of the left menu to choose tab diameter and thickness, then click on the model to add a tab at each point you think is at risk of warping or poor adhesion (typically parts with low surface area in contact with the print surface in relation to their height). These new tabs can now be moved around to fine tune their position using the normal move controls on Cura.

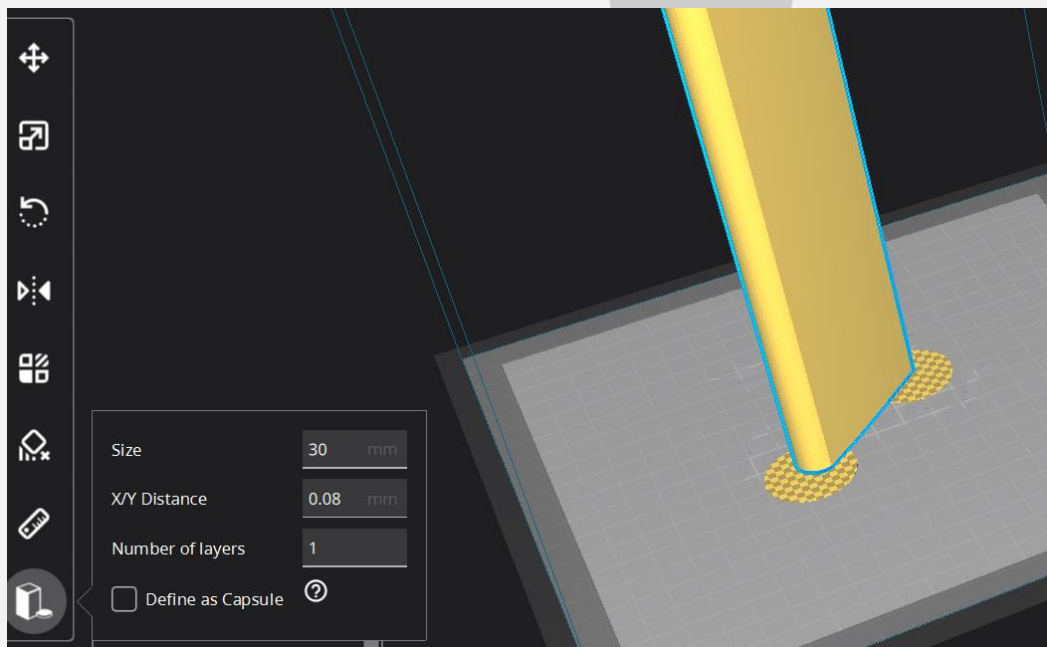

Once completed, be careful when removing these tabs as they are quite strong and can damage the bottom of your part if not removed carefully. Re-open any holes the tab may have filled on the bottom of the print.



### 4.3 Parts List & Expected weights

Please note, Cura will not estimate the weight of LW-PLA correctly unless you set a material profile to use density around 0.6-0.8g/cm<sup>3</sup>.

The below table contains estimates based on the use of Polymaker Polylite prefoamed LWPLA and our slicer profile, your results may vary slightly depending on your printer, material and settings.

Part	Estimated Weight (grams)	Filament	Estimated Print Time
Canopy1	10.2	LW-PLA	2:23:00
Canopy2	22.8	LW-PLA	2:31:00
Fuse1	39.7	LW-PLA	4:17:00
Fuse2	79.3	LW-PLA	8:54:00
Fuse3	108	LW-PLA	12:16:00
Fuse4	50	LW-PLA	5:21:00
Fuse5	41.2	LW-PLA	5:03:00
Hstab1L/R	21.2	LW-PLA	1:45:00
Hstab2L/R	4.1	LW-PLA	0:23:00
Rudder	9.4	LW-PLA	0:55:00
Vstab1L/R	15.6	LW-PLA	1:21:00
Vstab2 L/R	2	LW-PLA	00:22
Wing1L/R	79.1	LW-PLA	8:35:00
Wing2L/R	72.7	LW-PLA	7:44:00
Wing3L/R	55.5	LW-PLA	5:35:00
ElevatorL/R	12.2	LW-PLA	1:15:00
Hatch1	20.5	LW-PLA	1:45:00
Hatch2	17.8	LW-PLA	1:30:00
FlapL/R	18.5	LW-PLA	2:50:00
Wingtip-downL/R	56.5	LW-PLA	5:47:00
AileronL/R	16.5	LW-PLA	1:54:00
Fpv_fuse2	83.3	LW-PLA	9:11:00
Fpv_fuse1	48.4	LW-PLA	5:16:00
Fpv_lower_canopy_large servo_hole	29.7	LW-PLA	3:16:00
Fpv_lower_canopy_2	30.1	LW-PLA	3:20:00
Flap_Bay (HT)L/R	7	PC/PETG	1:10:00
Aileron_bay-L/R (HT)	15.4	PC/PETG	3:20:00
Nacelle_cap (HT)L/R	9.3	PC/PETG	1:11:00

**Note:** Aim for a dry weight of 2.2kg without battery, and maximum take-off weight of 6.6kg (feel free to push it past that if you dare). A nice all-up-weight is 3.5kg.



## Section 5: Assembly of 3D Printed Parts

The spar layout for Falcon is as depicted below. None of the spars need to be glued in, they will all be retained by the printed parts. The two 1-meter 12mm diameter spars are the joiners for the wings and the fuselage and can be removed completely from the fuselage and wing during transport.

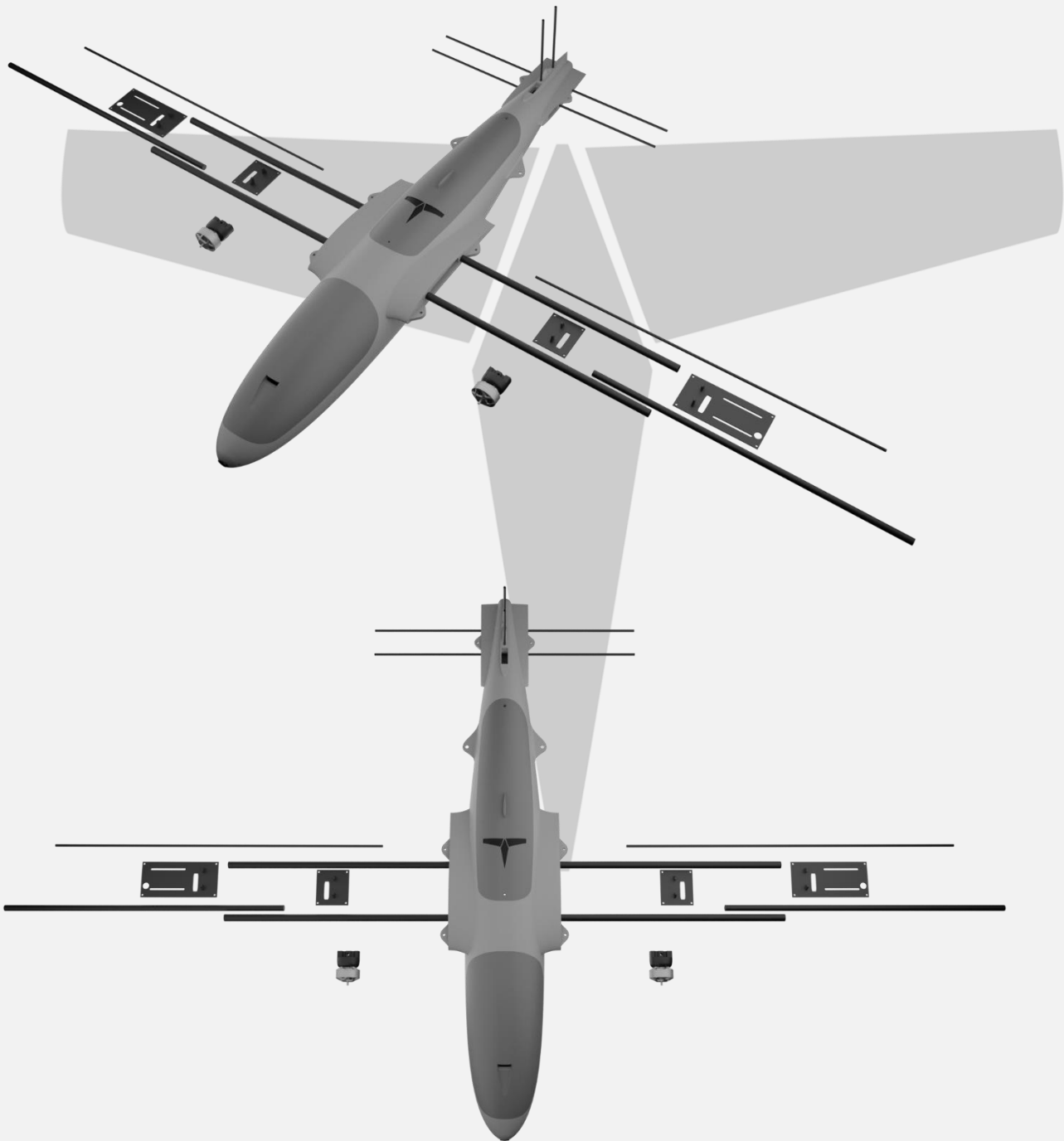



Below are a few exploded views of the Falcon to help with assembly.

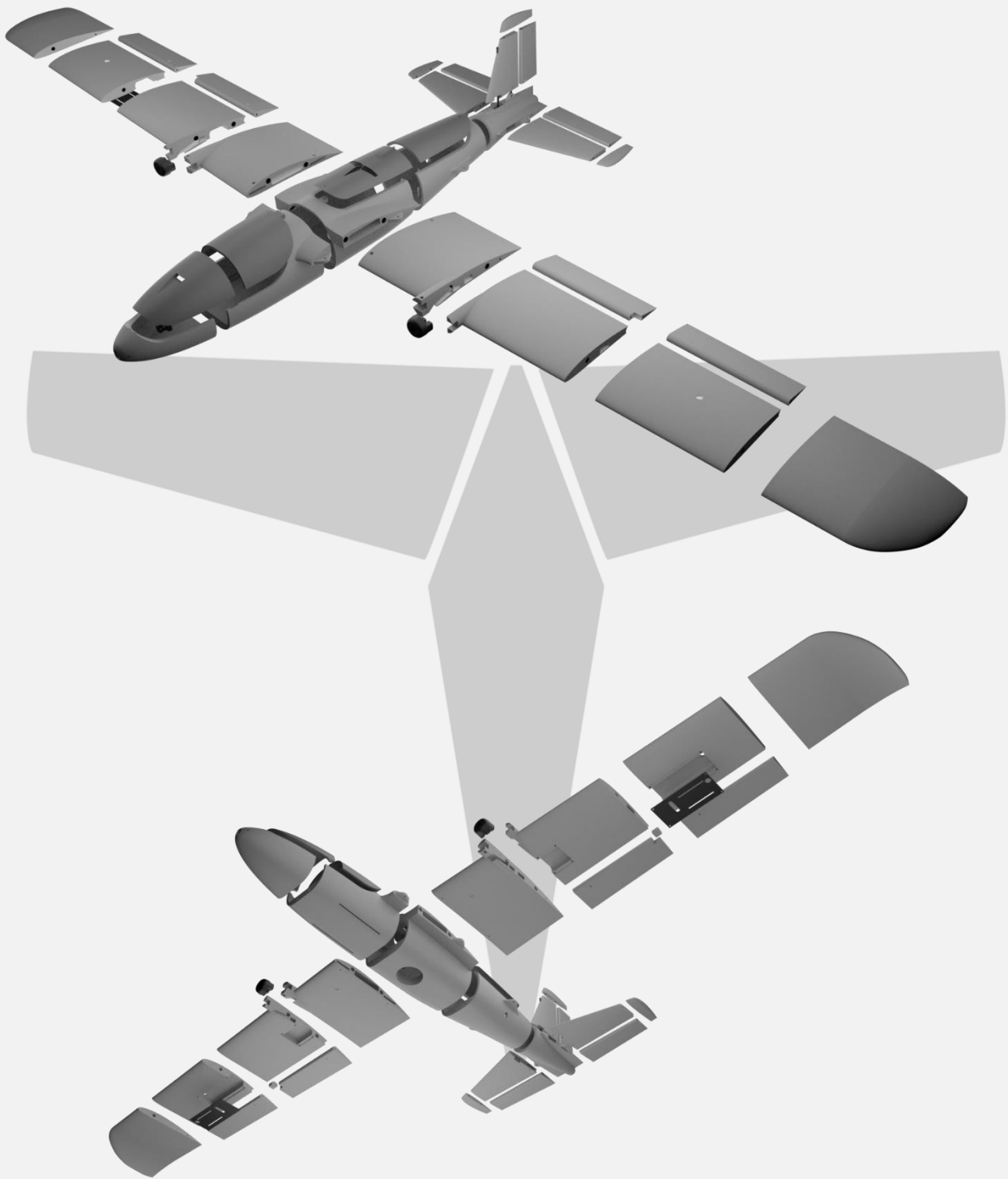



Titan Dynamics

[Titan Dynamics Webpage](#)

[Visit our Facebook page](#)

[Join our Discord server](#)

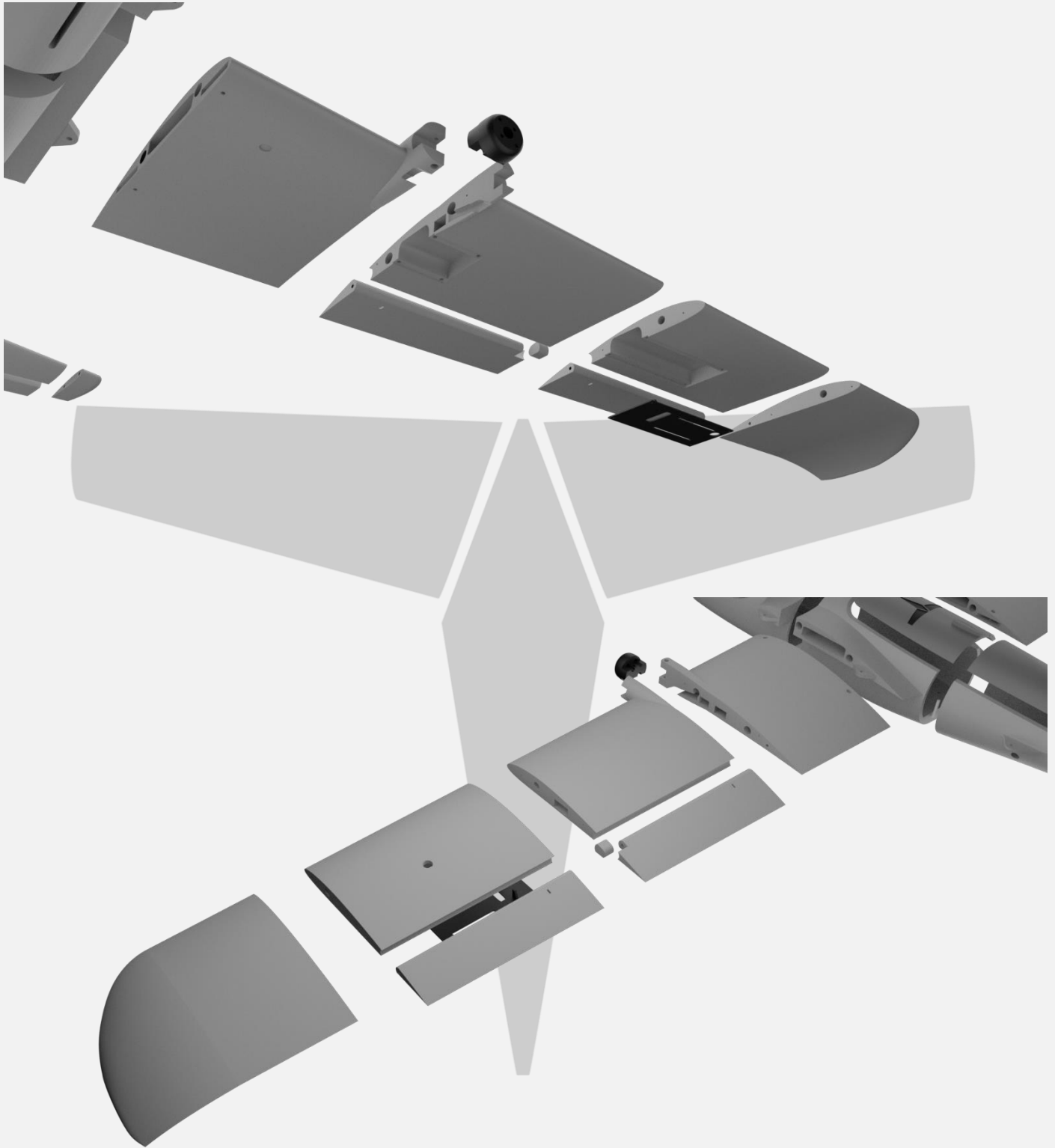



Titan Dynamics

[Titan Dynamics Webpage](#)

[Visit our Facebook page](#)

[Join our Discord server](#)

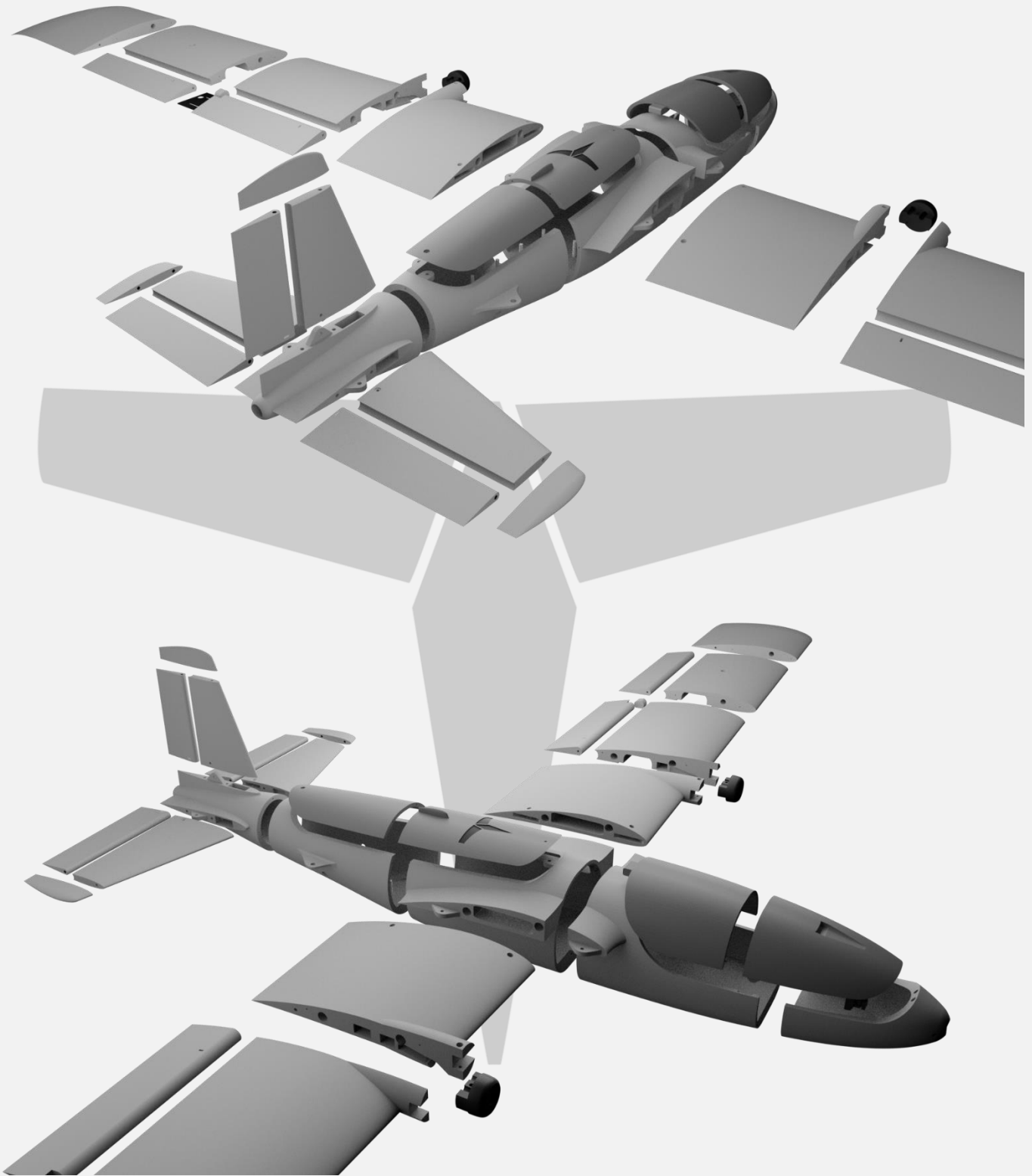



- Medium CA glue should be used to assemble all fuselage parts, some parts have small alignment holes where a short piece of 1.75mm filament can be used to help align the parts properly. This is optional as the parts can be aligned manually quite easily and they do not provide any added strength to the final product.
- When first putting the glued parts together be sure to wipe any excess glue off before it sets. A kicker may then be used to speed up the setting time; technically this results in a weaker joint, however it will still be stronger than the base material LW-PLA.
- Small pieces of filament can be inserted into the alignment holes to help guide the fuselage pieces together. The filament won't be perfect, so care must be taken to align the pieces to the best of your ability.

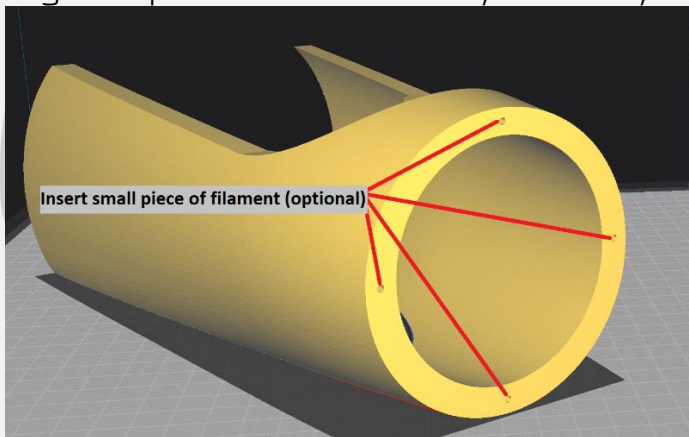

- When gluing the wings together, use the carbon rods to ensure alignment however be careful not to glue them in, they should not be glued in on the final product.
- Do not glue the wing tips on until you have the carbon rod and aileron/flap installed as it's the wing tip that secures these in place. If you glue the wing tip on before inserting the control surfaces + carbon rod you will not be able to insert them afterwards.
- The small guide piece (flap\_aileron\_middle\_support) is meant to be glued in between the flap and aileron to aid rigidity of the flap and aileron hinge spar. Our prototype that we printed and tested with did not include this piece, but it can provide some piece of mind for long term use.
- Threaded inserts can be properly installed by using a soldering iron, a good guide for doing this can be found at [this link](#).



## Section 6: Final Setup & Tuning Tips

- Titan Dynamics strongly recommend the use of Arduplane for all our models.
- Give all control surfaces +/- 35 degrees or more throw. Flaps can go down up to 45 degrees.
- Setup motor rotation such that props rotate inwards towards the fuselage, for added torque roll during differential yaw.
- Take-off does not require flaps, but landing can be done easier with half flaps.
- CG is marked under the wing, however is very forgiving +/- 10mm.
- Add duct tape or other abrasion resistant material to bottom of the fuselage to increase durability if landing on rough surfaces. Single wall prints are prone to rocks puncturing the bottom of the fuselage, and a strong layer of tape can greatly increase the Falcon's lifespan.

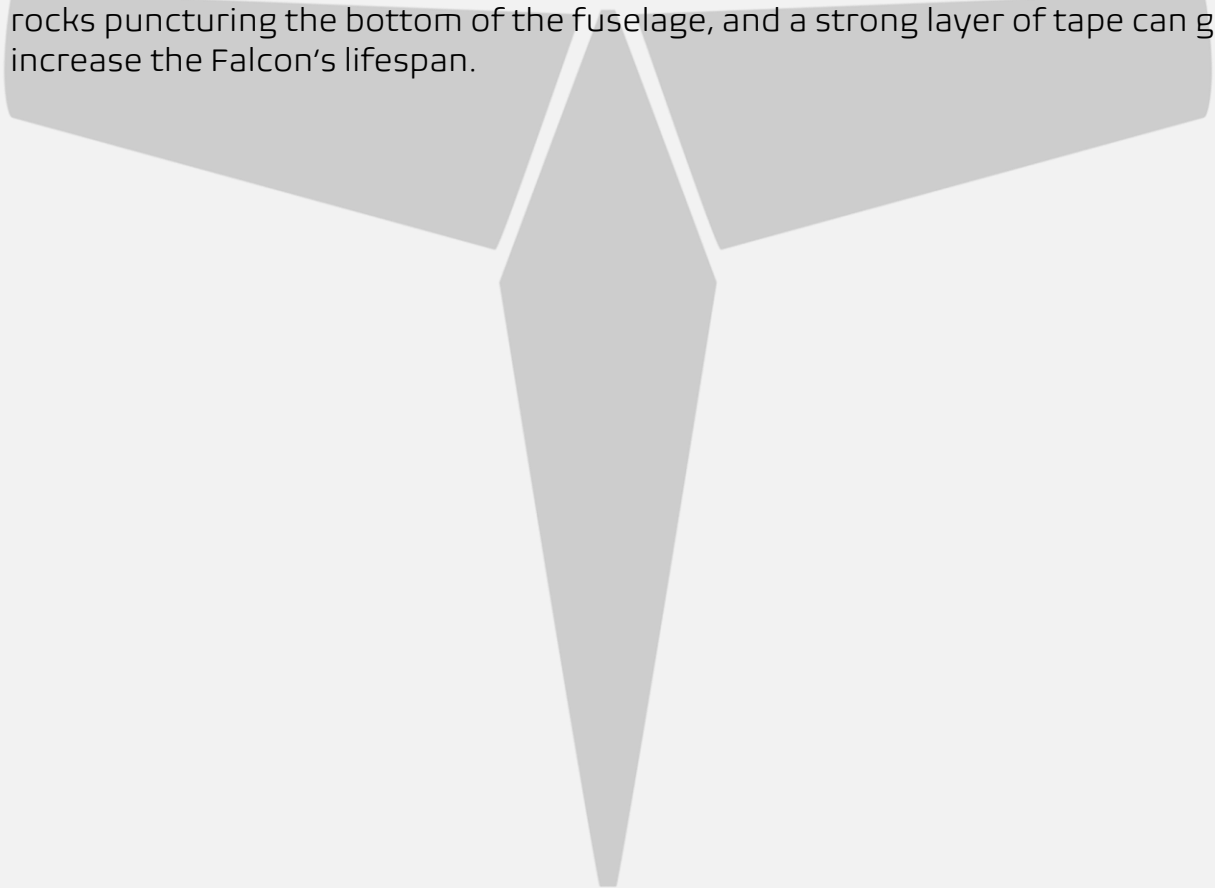





## Section 7: Images

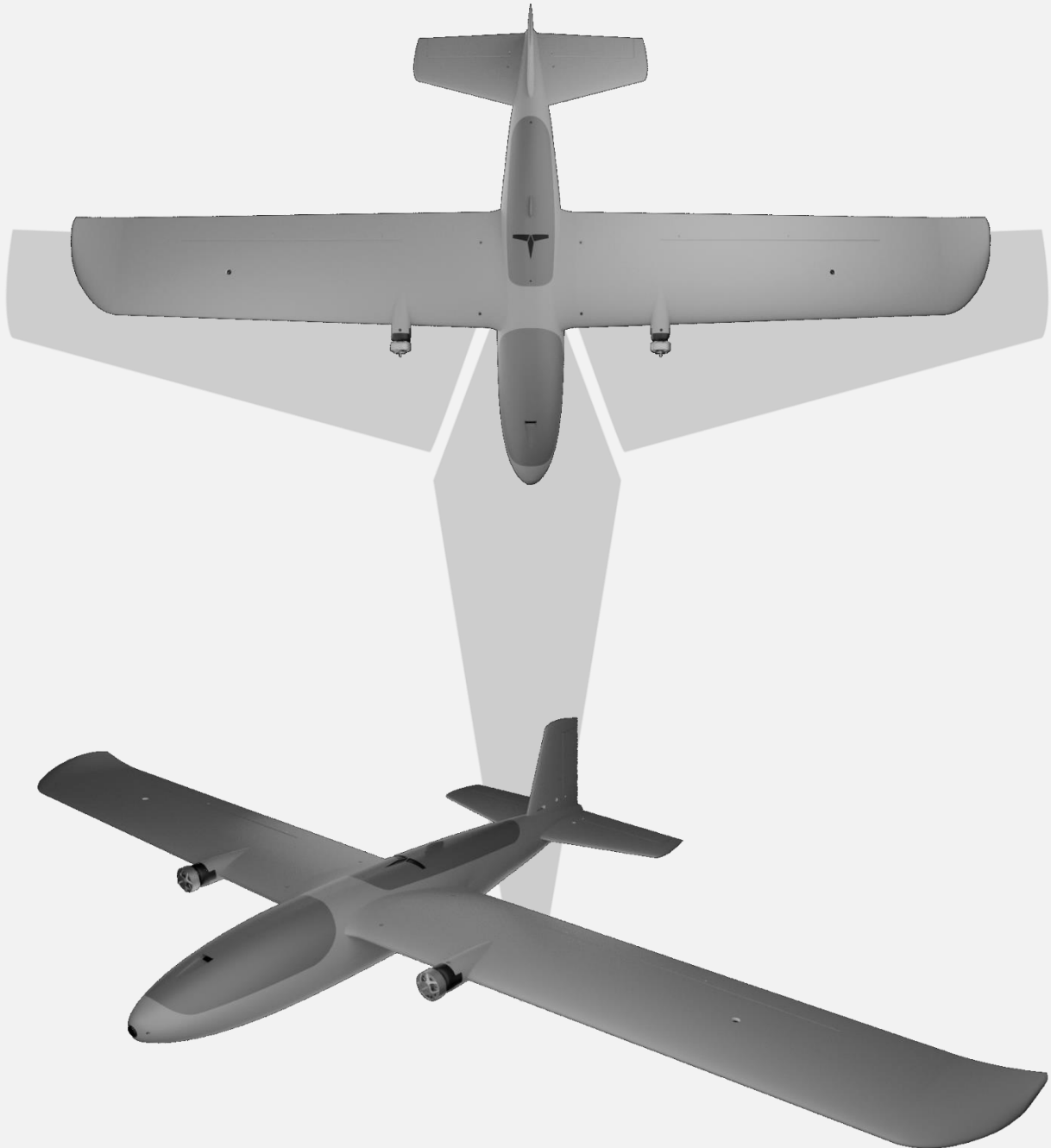



Titan Dynamics

[Titan Dynamics Webpage](#)

[Visit our Facebook page](#)

[Join our Discord server](#)

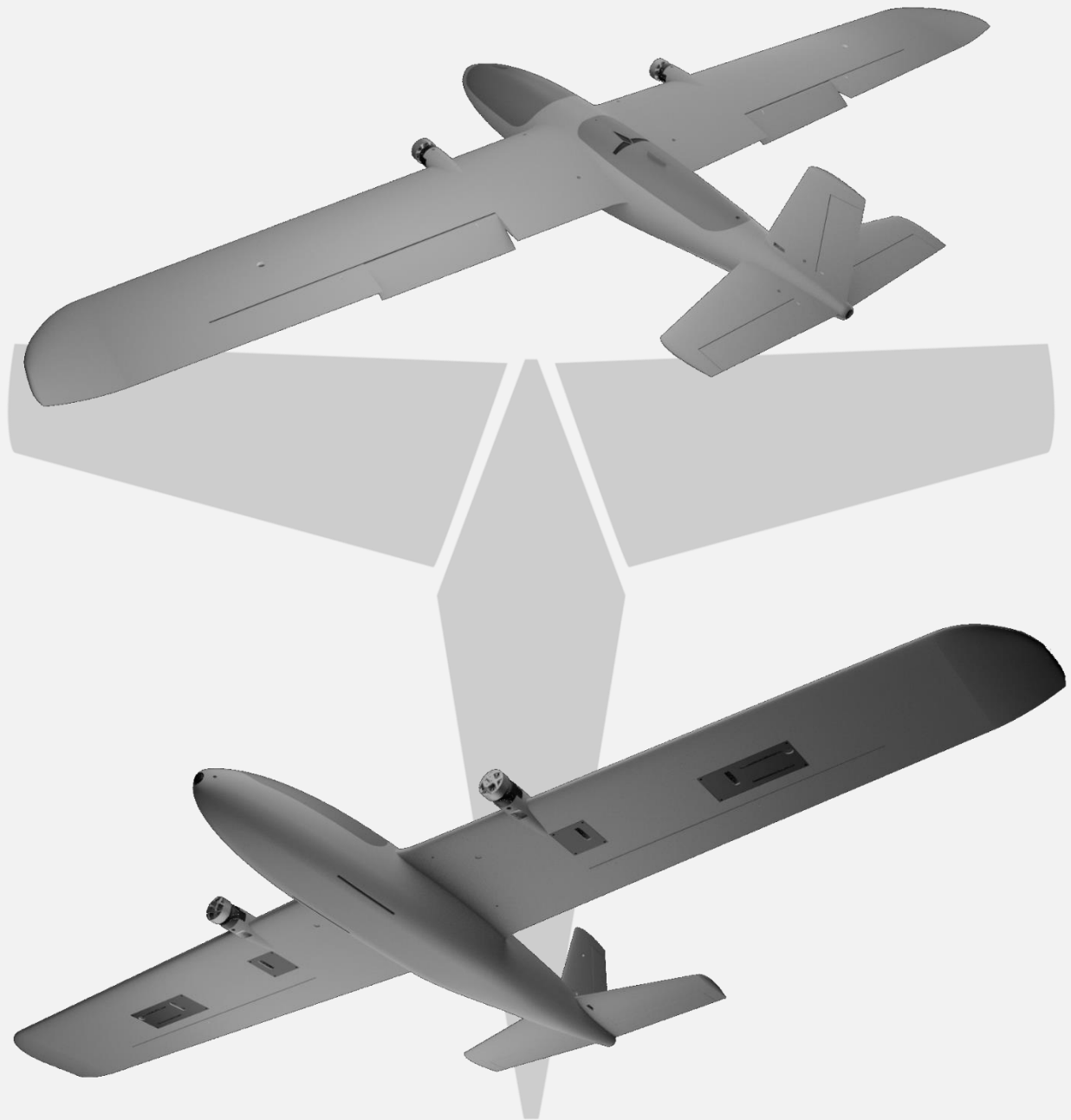



Titan Dynamics

[Titan Dynamics Webpage](#)

[Visit our Facebook page](#)

[Join our Discord server](#)

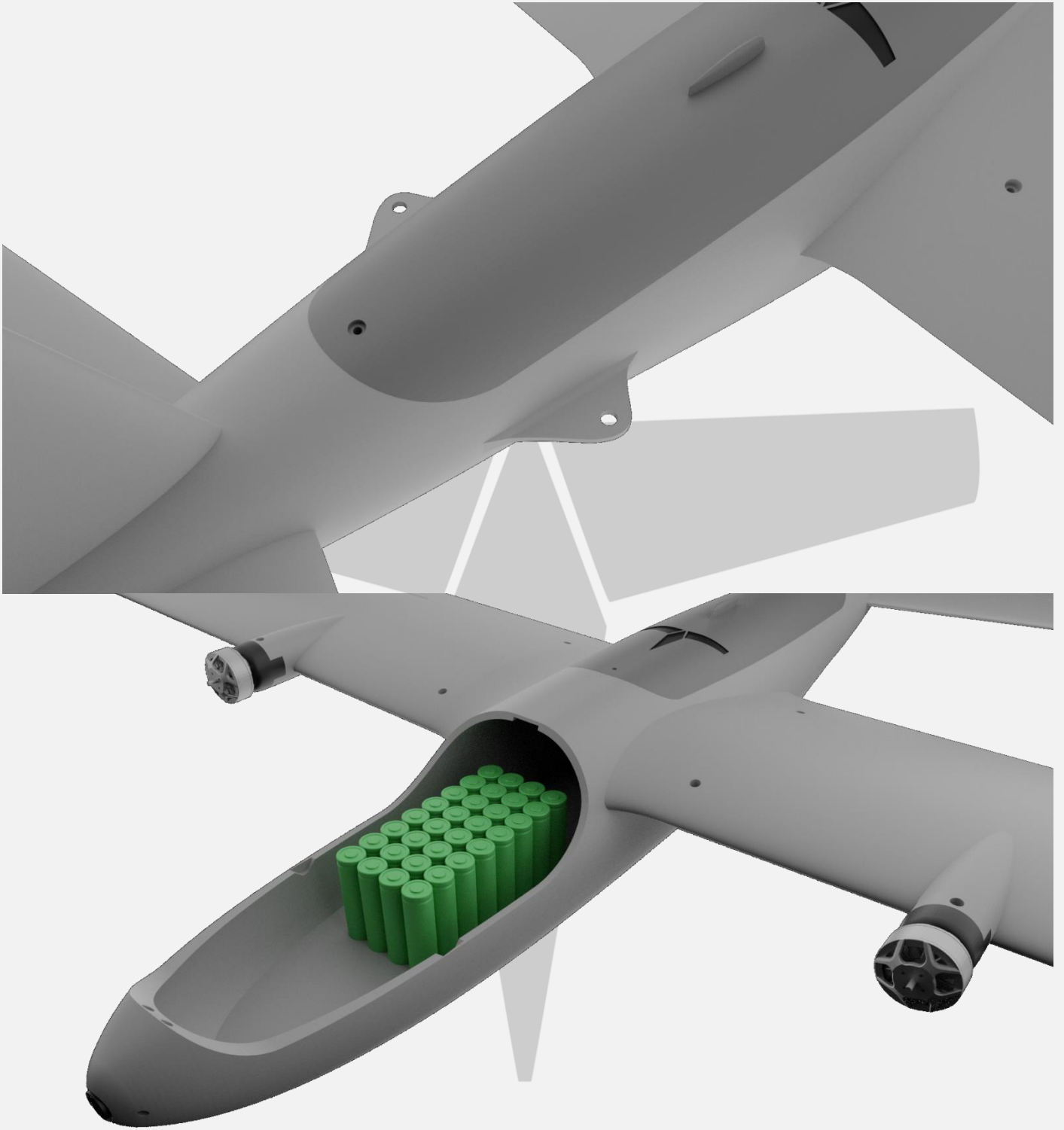



Titan Dynamics

[Titan Dynamics Webpage](#)

[Visit our Facebook page](#)

[Join our Discord server](#)

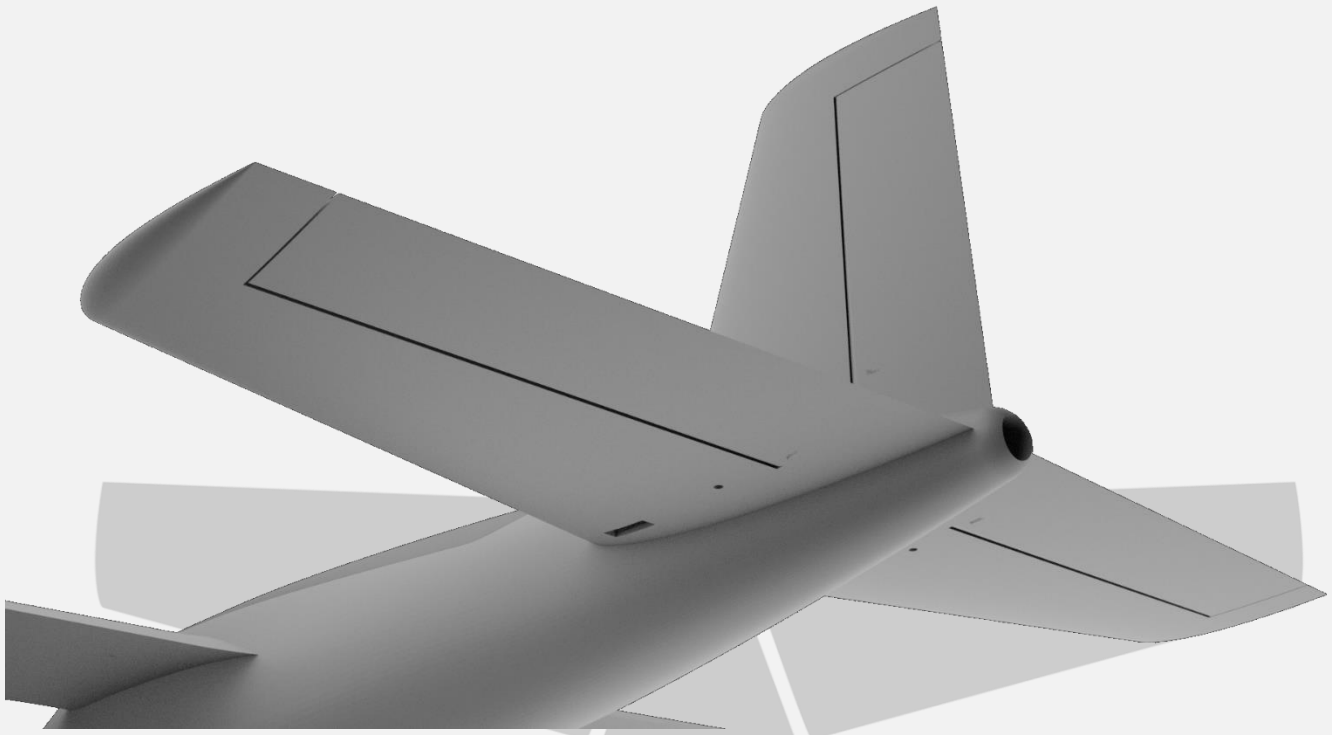

Mapping Camera Option:

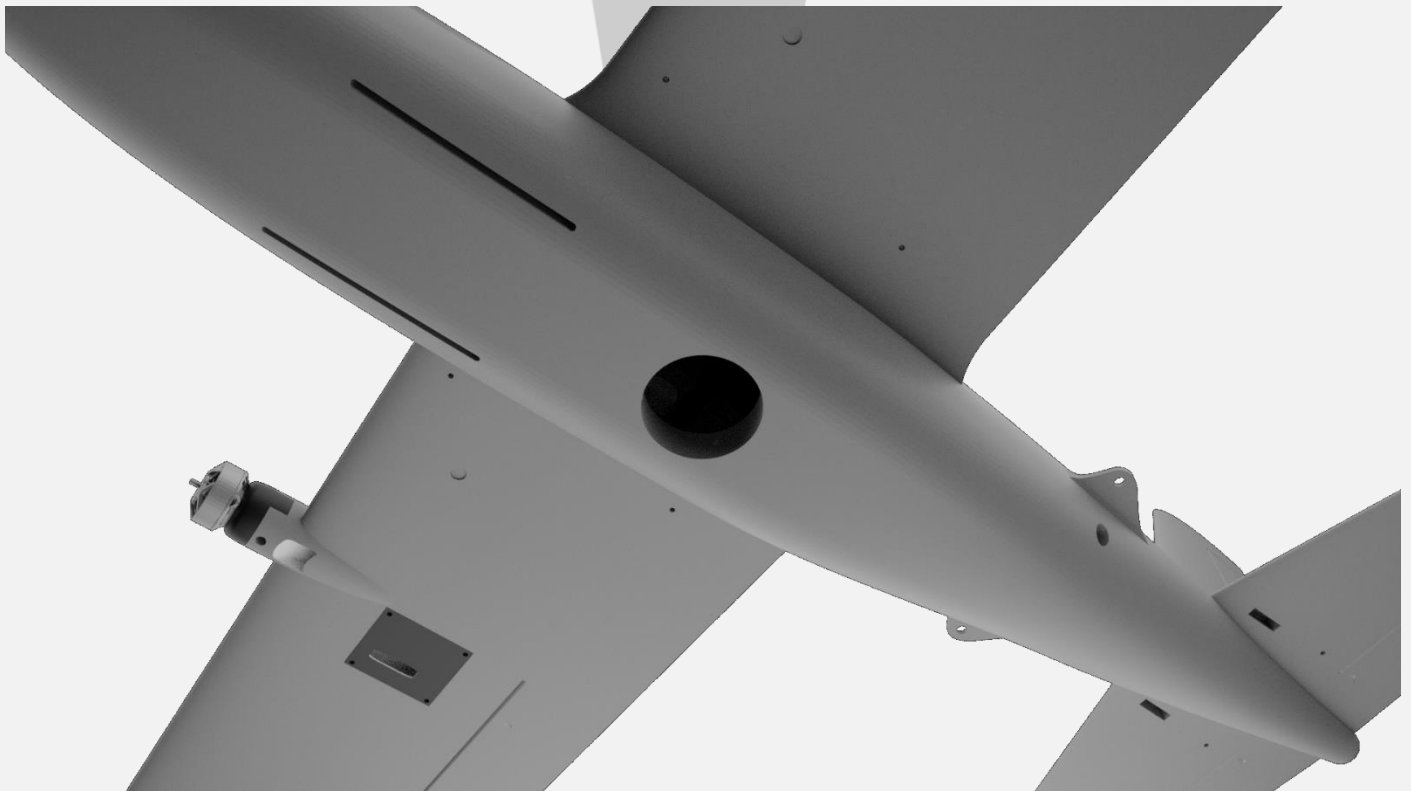



Canopy Options:

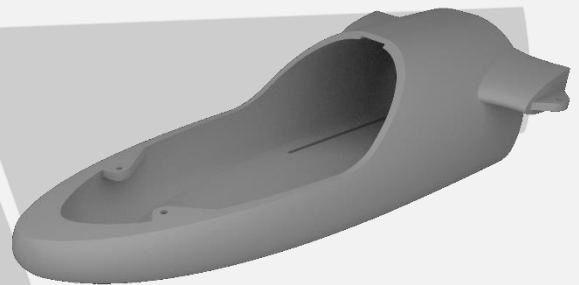
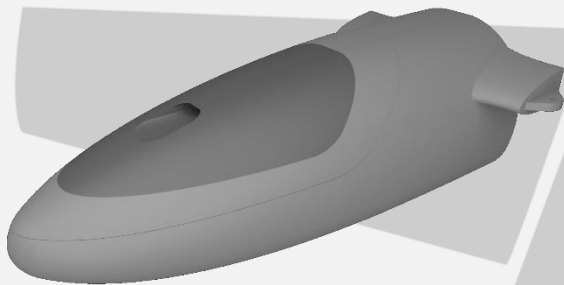
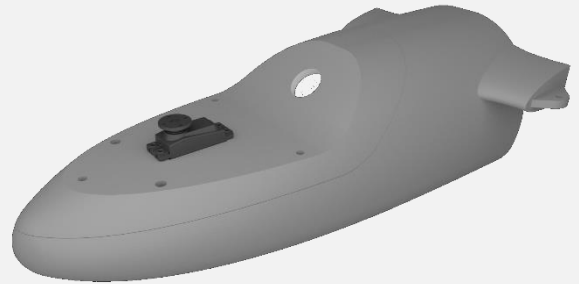
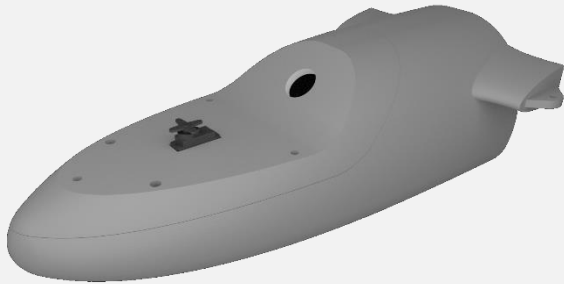



## Wing Tip Options:

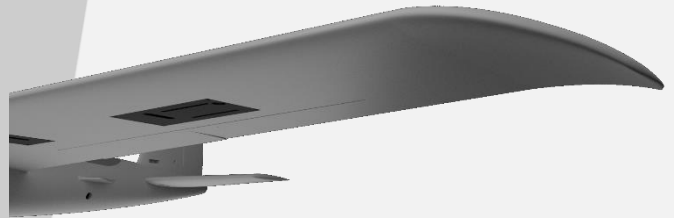
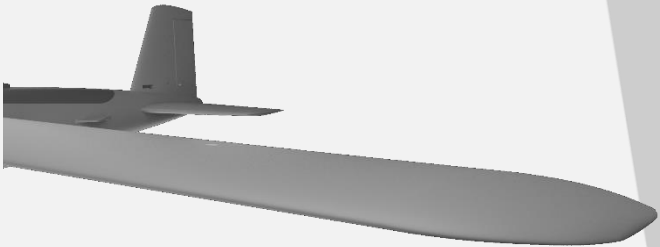
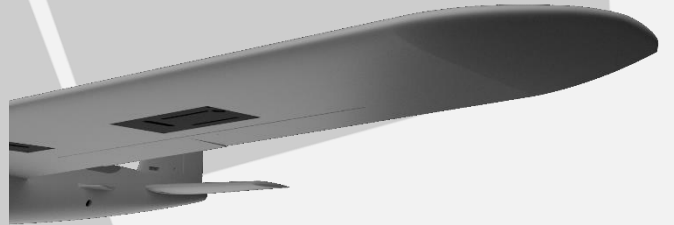
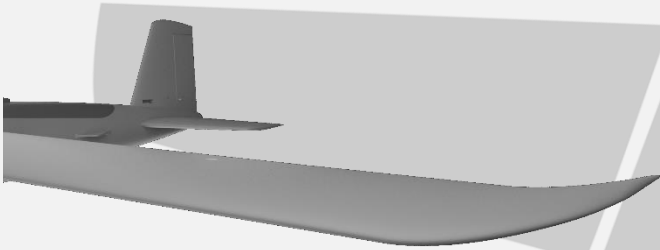
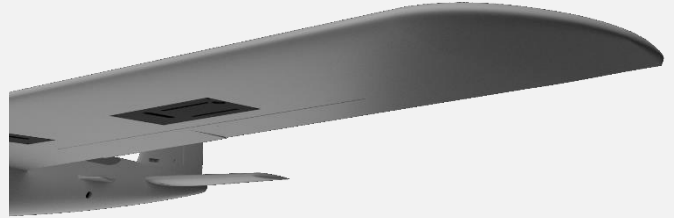
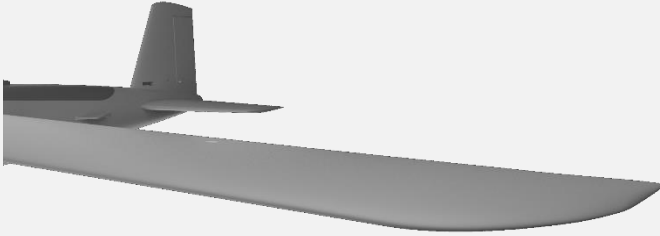



Titan Dynamics

[Titan Dynamics Webpage](#)

[Visit our Facebook page](#)

[Join our Discord server](#)

NEW 2023 Vtail Mod: Please print fuse5 in the Vtail folder when printing fuselage

